

Further technical data for HORST1000 robot system.

Technical data version: **V230228**

1 Technical data - HORST1000

Robot	HORST1000
Number of axes	6
Maximum payload	8 kg
Nominal load	5 kg
Max. range	1018 mm
Repeatability	+/- 0.05 mm
Protection classification	IP54
Sound level	<70 dB (A)
Weight	ca. 70kg
Power supply	230 VAC, 50-60 Hz, typically: 350 W
Ambient temperature	5-40 °C
Installation area (L x W)	380 x 380 mm
Base drilling pattern	300 x 300 mm
Standard color	RAL 5021 (water blue)

2 Axis data - HORST1000

Axis	Range of movement	Speed (With a payload of 0 kg; rounded down)
1	+/- 176°	225 °/s
2	+103° / +5°	95 °/s
3	+57° / -66°	280 °/s
4	+/- 171°	980 °/s
5	+/- 119°	880 °/s
6	+/- 300°	1150 °/s

The maximum axis speeds were determined with a payload of 0 kg as this is the only way to ensure that the measured values can be compared properly. At maximum payload, the maximum speed can vary greatly since it depends directly on the position of the center of mass. The maximum speed at 0 kg payload, on the other hand, is unambiguous as the influence of the center of mass of a payload does not apply.

In general, speed is rather less suitable as a basis of decision-making in robot selection, as it only shows the actual performance of a robot to a limited extent. Depending on the range of motion and the motion profile of the application, high accelerations, for example, can have a significantly greater influence on cycle time and economic efficiency than speed. It is therefore recommended to analyze the application with the corresponding framework conditions by using horstFX Web¹ or via a feasibility analysis, for example.

¹ <https://horstcosmos.com/apps/horstfxweb>

3 Technical data Control

Control	
Dimensions (H x W x D)	313 mm x 174 mm x 446 mm
Weight	ca. 10 kg
Protection classification	IP20
I/O connections on switch cabinet	20 digital inputs (expandable to 28) 18 digital outputs (expandable to 30)
I/O connections on tool flange	2 digital inputs and outputs each M8 male, 4-pin, angled, A-coded
I/O power supply	24 V/7 A at control 24 V/2.5 A at tool flange
Communication	TCP/IP 100-Mbit/s Ethernet [Web interface via HTTP]
Fieldbuses	Modbus/TCP Profinet (Activation of the interfaces via horstFX extension "horstFX External")
Safety-relevant Interfaces (2 channels each)	Emergency stop [input and output] Safety stop [input and output] In accordance with DIN EN ISO 10218-1; PL d. + 4 config. safe inputs (also configurable as 8 digital inputs) + 6 config. safe outputs (including 2 potential-free contacts)
USB ports	2x USB port 3.0
Wiring of HORST	3 m cable between robot and switch cabinet
Wiring of operating panel	5 m cable between operating panel and switch cabinet

4 HORST1000 Base drilling pattern

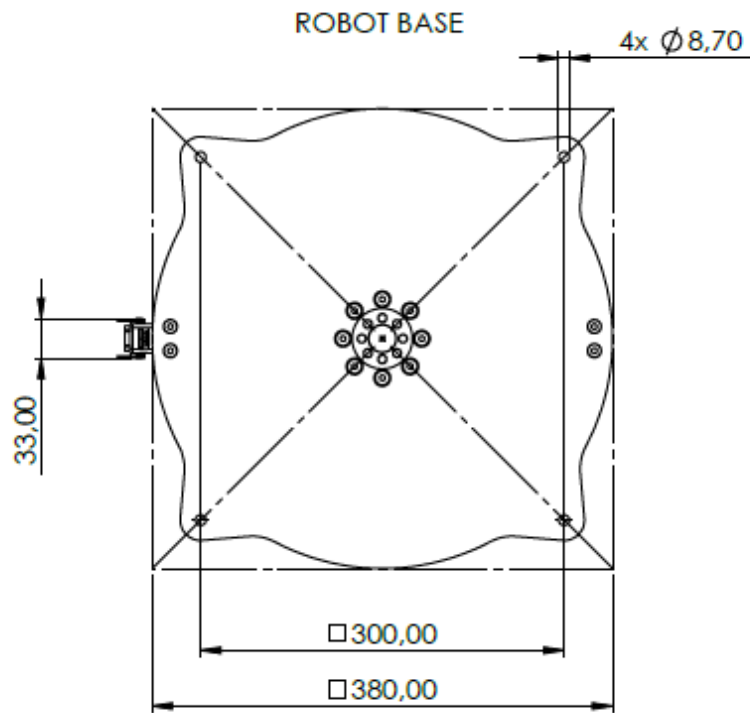

Base drilling pattern of HORST1000

5 Illustration robot flange

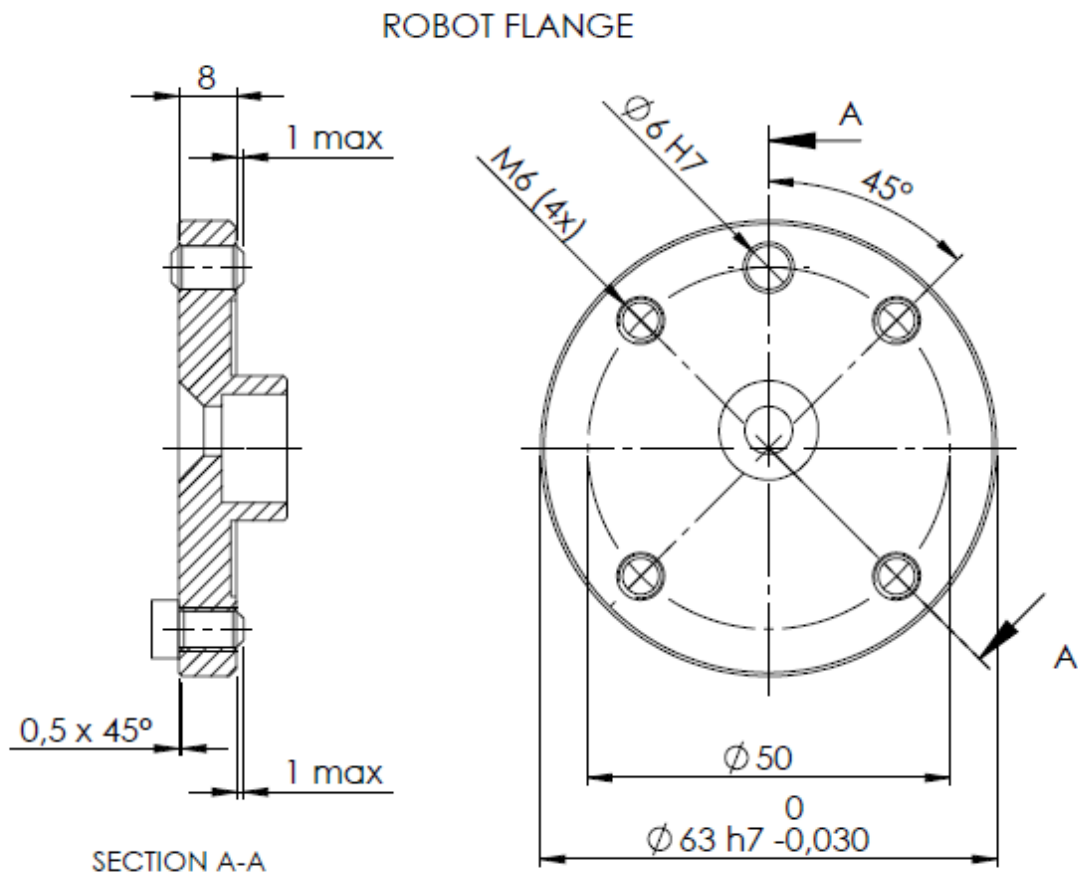

Flange of all HORST robot models

6 HORST1000 Workspace

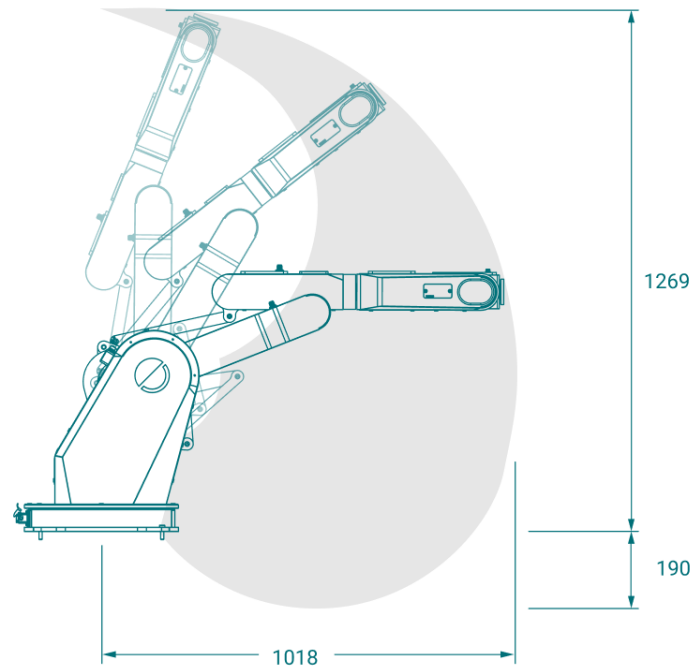

HORST1000 workspace – side view

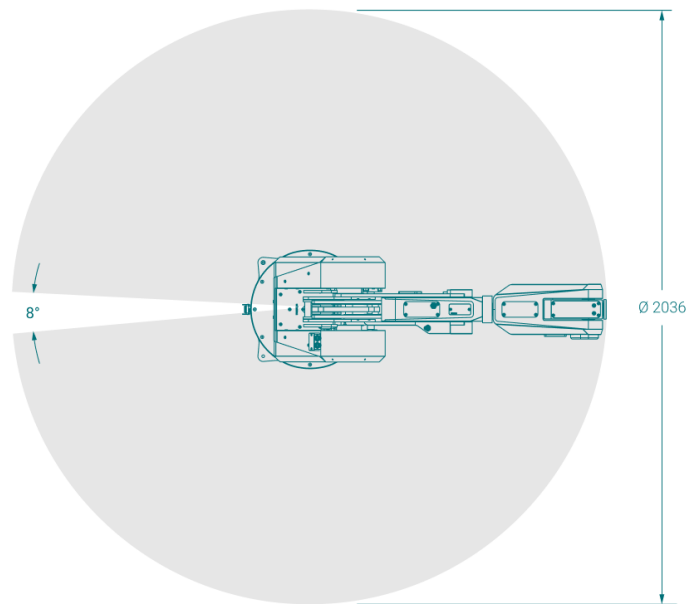

HORST1000 workspace – plan view

7 Flange plates (optional accessories)

Accessory flange plates can be used for attachments intended to be mounted on the robot arm (e.g. pneumatic valves). Mounting points with distances of 45 mm, 50 mm, and 60 mm hole spacing are available on the robot. The flange plate is designed with slotted holes and can therefore be used universally. Flange plates are optional accessories and are not included as standard in the scope of delivery of a robot system.

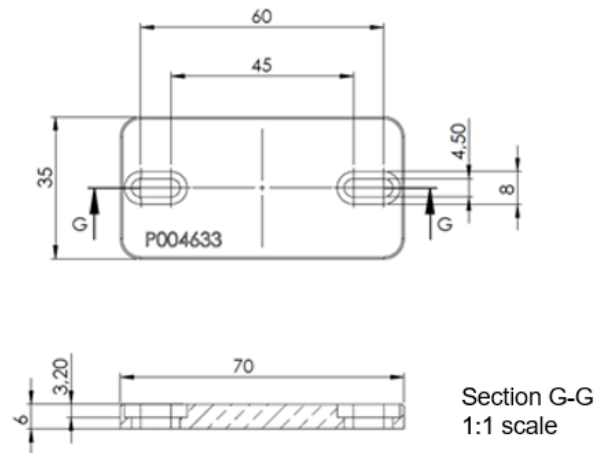

The mounting points are provided at the positions shown in the following figure:

