

**i** Technical data for the HORST800 G2 robot system  
Technical data version V260409

## 1 Technical Data - HORST800 G2

<b>Robot</b>	HORST800 G2
<b>Number of axes</b>	6
<b>Permitted installation</b>	Floor, overhead, angled
<b>Maximum payload</b>	6 kg
<b>Nominal load (according to VDI 2861-2)</b>	5 kg
<b>Max. range</b>	840 mm
<b>Repeatability</b>	+/- 0.05 mm
<b>Protection classification</b>	IP65 (axes 5 and 6) / IP54 (rest of the robot structure)
<b>Cleanroom class according to ISO 14644-1</b>	ISO 6 / ISO 5 *
<b>Sound level</b>	<70 dB (A)
<b>Weight</b>	40 kg
<b>Power supply</b>	230 VAC, 50-60 Hz
<b>Ambient temperature</b>	5-40 °C
<b>Base drilling pattern</b>	200 x 100 mm

\* ISO 5 depending on the specific application. Consideration on a case-by-case basis in consultation with fruitcore robotics

### Information on load capacity

The nominal load is determined in accordance with VDI 2861-2. The load center of gravity has a defined distance from the robot flange (for HORST800 G2:  $L_{xy} = 48$  mm;  $L_z = 83$  mm). The nominal load can be moved with these distances of the load center of gravity without restrictions in the entire working area of the robot.

It is possible to move loads above the nominal load with the robot. This is possible if the load is attached closer to the robot flange or by restricting the robot's working area. Please consult fruitcore robotics if loads greater than the nominal load are to be moved.

## 2 Axis data HORST800 G2

Axis	Range of movement	Speed Floor installation**; with a payload of 0 kg
1	+/- 171°	350 °/s
2	+152° / -80°	200 °/s
3	+77° / -198°	312 °/s
4	+/- 176°	840 °/s
5	+/- 158°	660 °/s
6	+/- 300°	1000 °/s

\*\* Different speeds in other mounting positions (overhead, wall-mounted, angled).

 The maximum axis speeds were determined with a payload of 0 kg as this is the only way to ensure that the measured values can be compared properly. At maximum payload, the maximum speed can vary greatly since it depends directly on the position of the center of mass. The maximum speed at 0 kg payload, on the other hand, is unambiguous as the influence of the center of mass of a payload does not apply.

In general, speed is rather less suitable as a basis of decision-making in robot selection, as it only shows the actual performance of a robot to a limited extent. Depending on the range of motion and the motion profile of the application, high accelerations, for example, can have a significantly greater influence on cycle time and economic efficiency than speed. It is therefore recommended to analyze the application with the corresponding framework conditions by using [horstOS Simulation](#)<sup>1</sup> or via a feasibility analysis, for example.

1. <https://horstcosmos.com/horstfx/options>

### 3 Technical Data Control

<b>Dimensions (H x W x D)</b>	313 mm x 174 mm x 446 mm
<b>Weight</b>	ca. 10 kg
<b>Protection classification</b>	IP20
<b>I/O connections on switch cabinet</b>	20 digital inputs (expandable to 28) 18 digital outputs (expandable to 30)
<b>I/O connections on tool flange</b>	2 digital inputs and outputs each M8 male, 4-pin, angled, A-coded
<b>I/O power supply</b>	24 V / 7 A at control 24 V / 2.5 A at tool flange
<b>Communication</b>	TCP/IP 100-Mbit/s Ethernet (Sockets), Primary interface (XML-RPC)  (The primary interface (XML-RPC) is activated via the “Advanced Interfaces” software option)
<b>Fieldbuses</b>	Modbus/TCP, Profinet, EtherCAT  (The interfaces Modbus/TCP, Profinet & EtherCAT are activated via the “Advanced Interfaces” software option)
<b>Safety-relevant Interfaces (2 channels each)</b>	Emergency stop [input and output] Safety stop [input and output] In accordance with DIN EN ISO 10218-1; PL d.  + 4 config. safe inputs (also configurable as 8 digital inputs) + 6 config. safe outputs (including 2 potential-free contacts)
<b>USB ports</b>	2x USB port 3.0
<b>Wiring of HORST</b>	3 m cable between robot and switch cabinet
<b>Wiring of operating panel</b>	5 m cable between operating panel and switch cabinet

## 4 HORST800 G2 Base drilling pattern

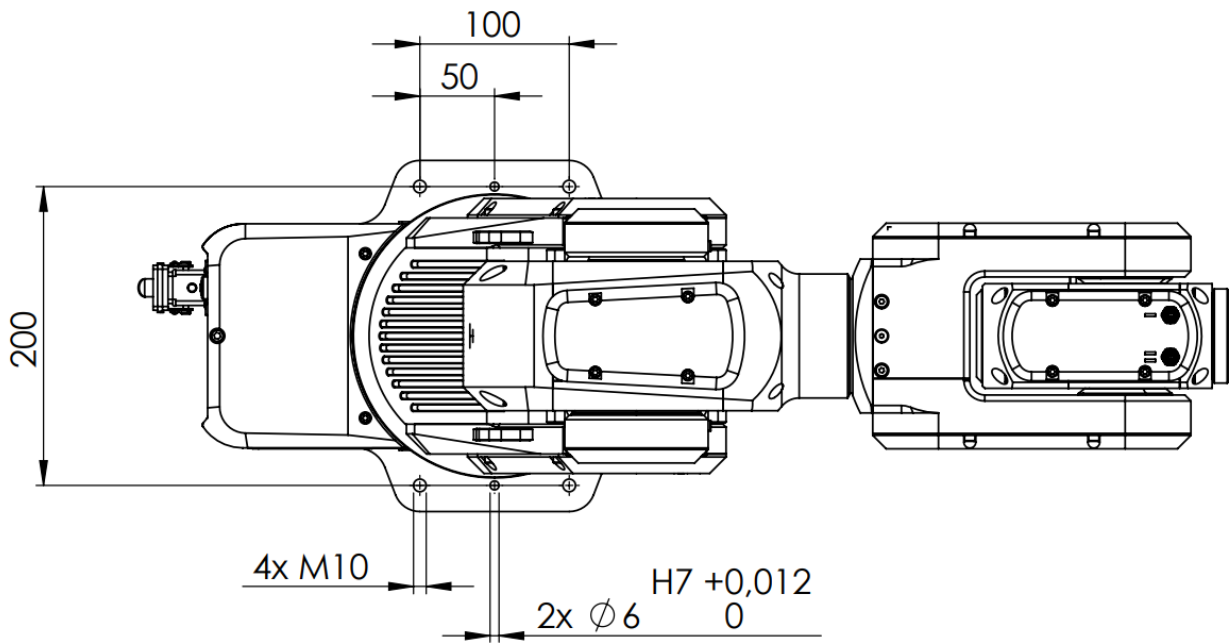

Dimensions of the base mounting pattern for the HORST800 G2 (top view)

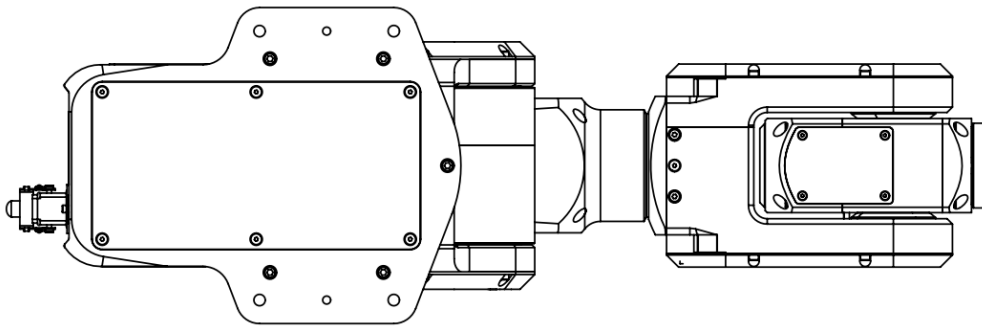

View of the HORST800 G2 from below

## 5 HORST800 G2 Robot flange

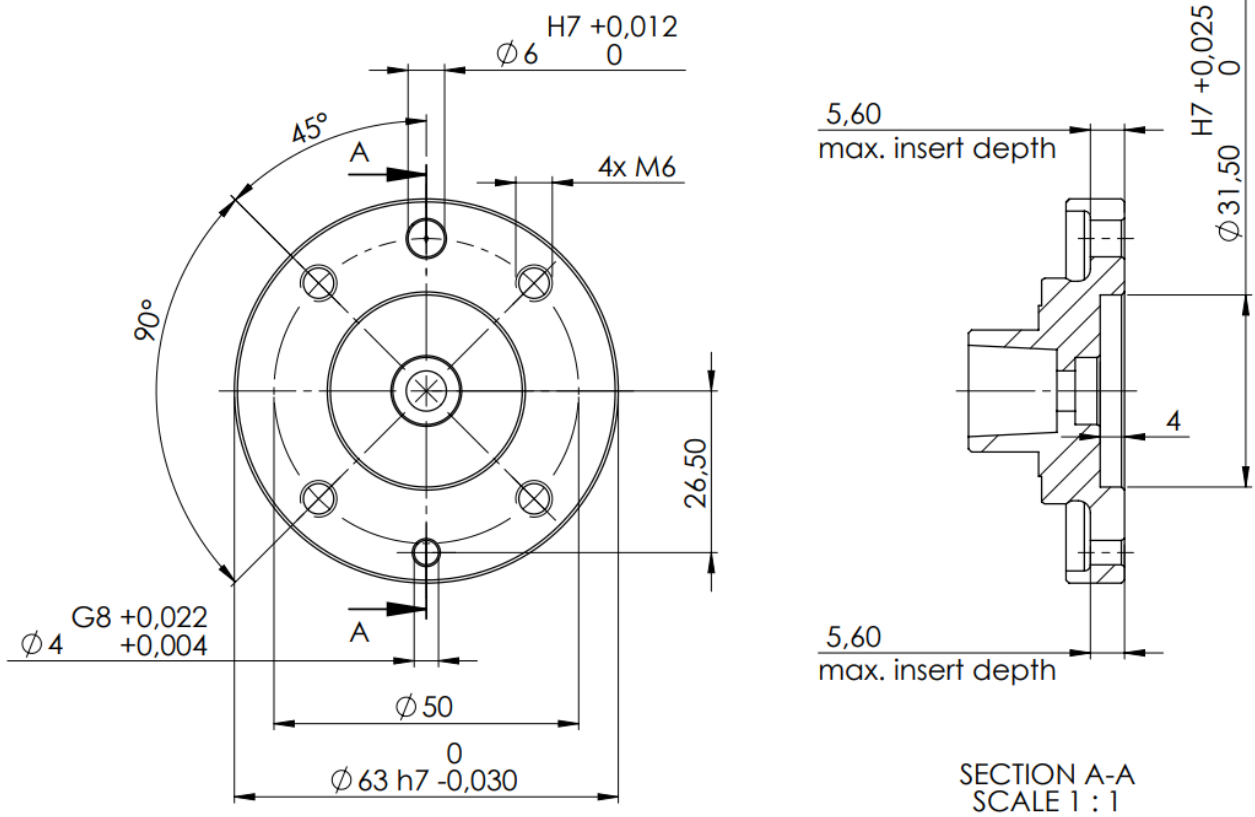

ROBOT FLANGE according to ISO 9409-1-50-4-M6  
SCALE 1:1

Robot flange of HORST800 G2

## 6 HORST800 G2 Workspace

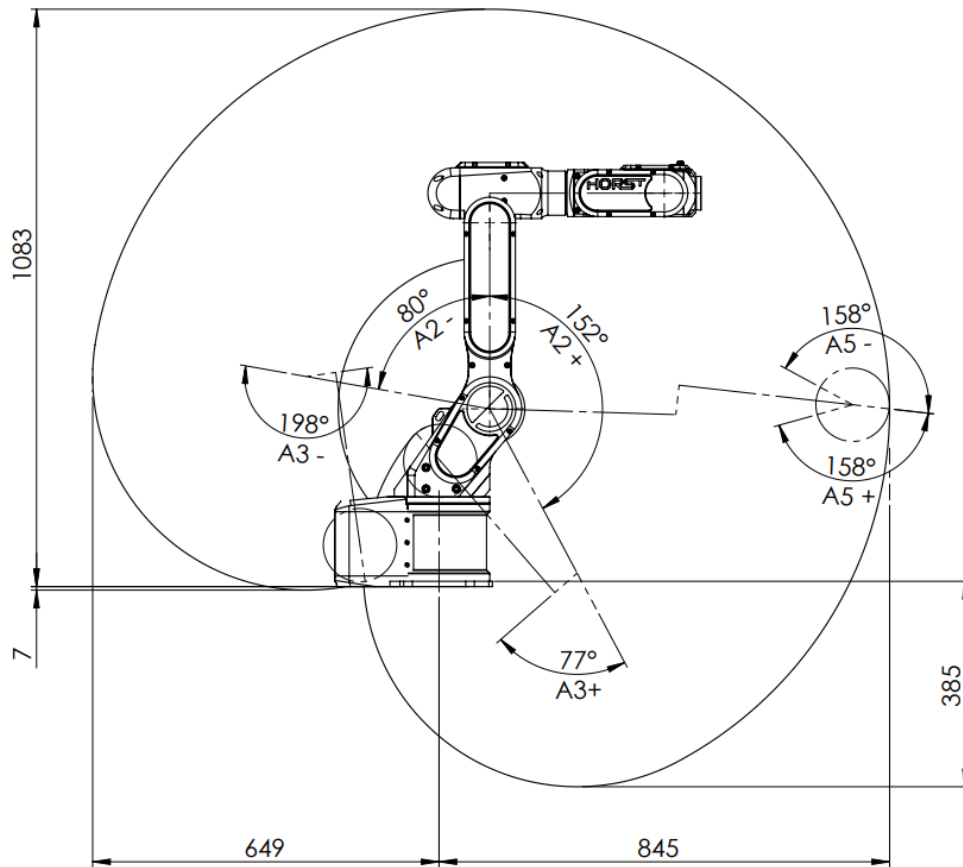

Side view of the work space of the HORST800 G2

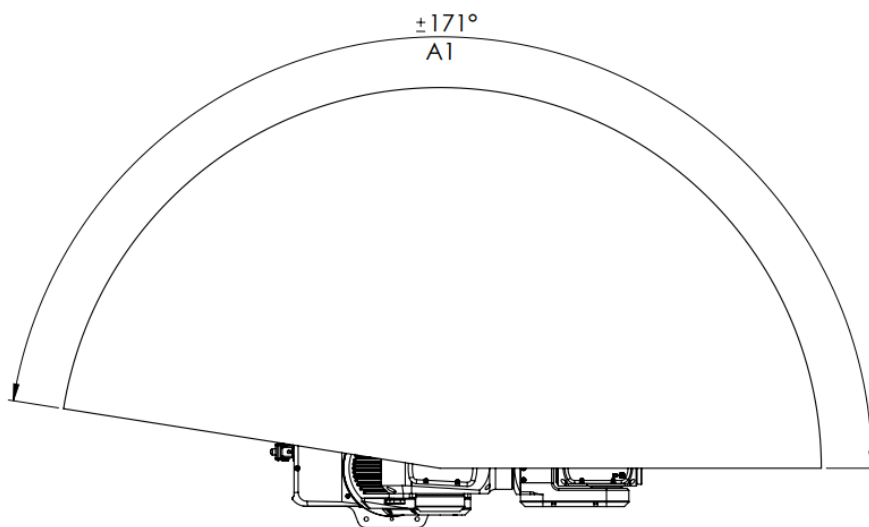

Top view of the HORST800 G2 work space